

## Transport and Base Plates

Zinc Die Casting, for Aluminum Profiles  
(i-Modular System)

### SPECIFICATION

#### Type

- Type **A**: Without screws  
Zinc die casting, black **ZS**

### INFORMATION

Transport and base plates GN 80i affix attachments such as leveling feet or castors to aluminum profiles. They are installed in the profile holes on the end faces using suitably tapped threaded holes or thread-forming screws. Transport and base plates can also be fastened lengthwise in the profile slot.



### ACCESSORY

- T-Nuts GN 50i (see page )

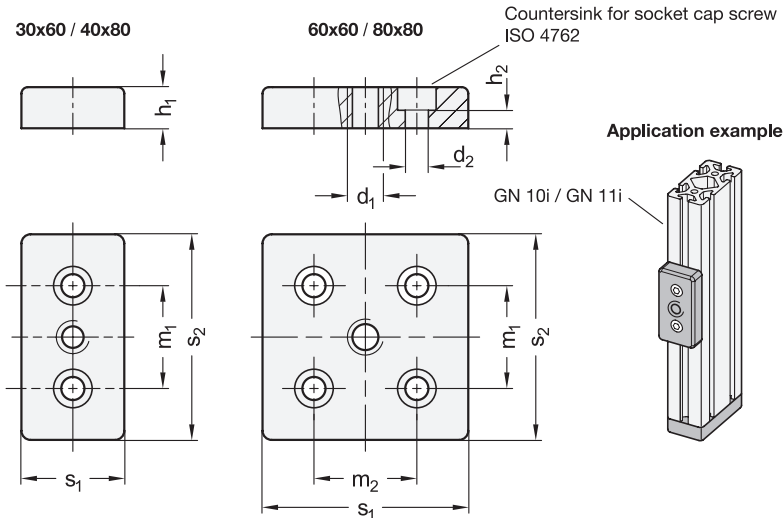

### GN 80i

Description	s1	s2	n	d1	d2 For screw	h1	h2	m1	m2	Grid size	
GN 80i-30606M8-A-ZS	30	60	6	M 8	M 6	12	5	30	-	30	103
GN 80i-30606M10-A-ZS	30	60	6	M 10	M 6	12	5	30	-	30	102
GN 80i-40808M10-A-ZS	40	80	8	M 10	M 8	16	6.5	40	-	40	211
GN 80i-40808M12-A-ZS	40	80	8	M 12	M 8	16	6.5	40	-	40	209
GN 80i-60606M10-A-ZS	60	60	6	M 10	M 6	12	5	30	30	30	193
GN 80i-60606M12-A-ZS	60	60	6	M 12	M 6	12	5	30	30	30	192
GN 80i-80808M12-A-ZS	80	80	8	M 12	M 8	16	6.5	40	40	40	443
GN 80i-80808M16-A-ZS	80	80	8	M 16	M 8	16	6.5	40	40	40	425

Assembly Instructions / Profile Machining

